



 **MATERIALLIFT[®]**

The Reid Material Lift (RML) offers two versatile configurations in one, conventional forward facing and counterbalance, with the ability to switch between the two, tool free in minutes.

Application Overview

Vertical material lifting presents a common challenge across many industries, where the need for increased productivity, versatility and safety is critical.

The RML provides solutions that can significantly improve these aspects, making it a key asset in a wide range of industries and applications such as:

- > M&E servicing and installation facilitation
- > Glass installment
- > Structural steel erection
- > General commercial & residential construction
- > Decommissioning and demolition work
- > Warehouse operations

Key features

- > **Full set of 360 castors with 2 locking castors** - Enables easier maneuverability of the unit at ground level and allows safer and easier micro adjustment when working at height
- > **Virtually silent winch** - This helps reduce noise emissions, benefiting 'live' worksite environments and where communication with the operators at height is key
- > **Easy to transport** - The RML comes equipped with standard horizontal, rough ground transport wheels, enabling the unit to be moved safely over uneven surfaces and into vehicles
- > **Unique rear pulley** - wide rear pulley allows even cable feed on to the winch drum giving smooth operation and less cable stress
- > **Quick change rear pulley** - Quickly remove the rear pulley with just a single bolt, streamlining repair times and minimising downtime.
- > **Hardwearing alloy pulleys** - standard across the range to increase service life and aid smooth operation
- > **No ball lock pins** - Detachable parts have a high chance of getting lost, that's why the RML uses captive plunger pins preventing lost pins that cause downtime
- > **Anti twist galvanised steel cable** - Cable replacement due to tangles and premature wear is common on other material lifts, to avoid this waste and additional operating cost we included a galvanised steel, anti-twist cable in all versions
- > **Tool free** - Easily converted from forward-facing to counterbalance configuration without the need for tools

Complies with Machinery Directive 2006/42/EC

Load Centre

Load centre is a key factor when considering using any RML system. Please refer to the Operations & assembly guide for more details.

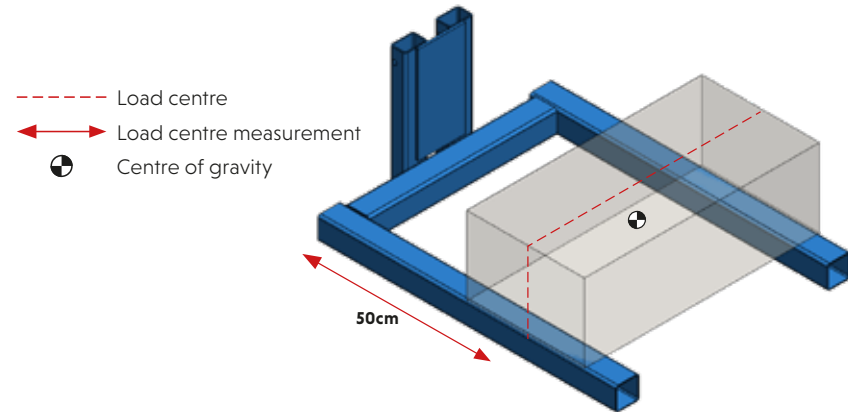

| | Forward Facing Load centre [cm] | | | | | | | |
|-------|---------------------------------|-----|-----|-----|-----|-----|-----|-----|
| | 0 - 40 | 50 | 60 | 70 | 80 | 90 | 100 | 107 |
| Model | Max [kg] | | | | | | | |
| RML30 | 450 | 450 | 450 | 370 | 295 | 265 | 240 | 225 |
| RML45 | 360 | 360 | 360 | 325 | 295 | 265 | 240 | 225 |
| RML60 | 360 | 330 | 270 | 235 | 200 | 185 | 165 | 155 |
| RML75 | 300 | 260 | 200 | 180 | 155 | 140 | 120 | 110 |



| | Counterbalance Load centre [cm] | | | | | | | |
|-------|---------------------------------|-----|-----|-----|-----|-----|-----|-----|
| | 0 - 40 | 50 | 60 | 70 | 80 | 90 | 100 | 107 |
| Model | Max [kg] | | | | | | | |
| RML30 | 450 | 370 | 300 | 250 | 200 | 165 | 135 | 120 |
| RML45 | 360 | 295 | 240 | 200 | 165 | 130 | 105 | 100 |
| RML60 | 360 | 295 | 240 | 200 | 165 | 130 | 105 | 100 |
| RML75 | 300 | 245 | 200 | 165 | 135 | 110 | 90 | 80 |

MATERIAL LIFT®



RML30



RML45



RML60

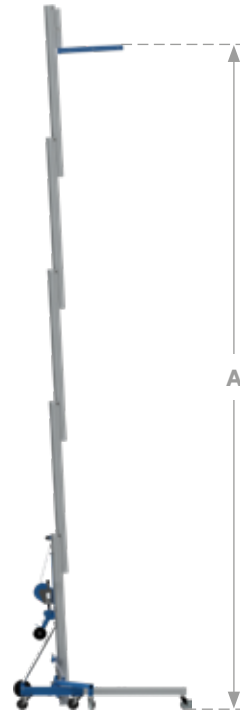

RML75

- A** Height of Lift
- B** Forward Facing Length
- C** Width
- D** Counterbalance Length
- E** Stowed Length
- F** Stowed Width
- G** Stowed Height

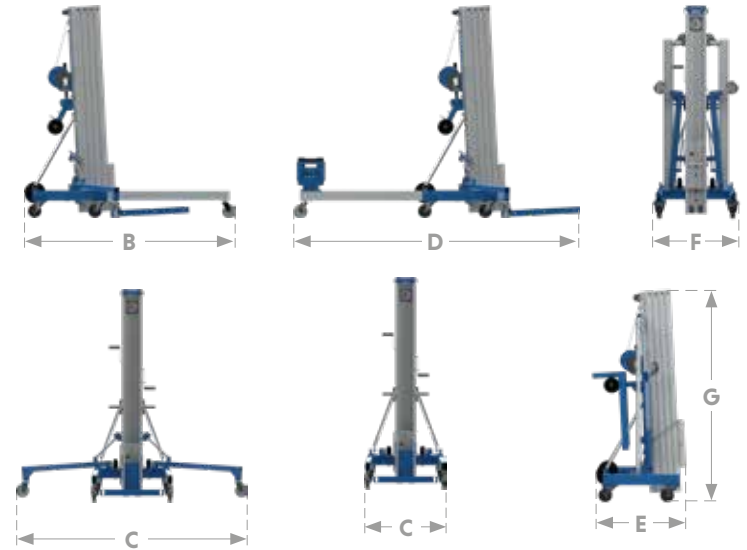

| Dimensions (mm) | | | | | | | | | |
|-----------------|--------------|------------------|---------------------|----------------------------|------------|-----------------------------|--------------------|-------------------|--------------------|
| Model | Max WLL (kg) | Unit Weight (kg) | A Height of Lift | B Forward Facing Length | C Width | D Counterbalance Length* | E Stowed Length | F Stowed Width | G Stowed Height |
| RML30 | 450 | 123 | 3000 | 1970 | 800 | 2670 | 785 | 800 | 2001 |
| RML45 | 360 | 146 | 4500 | 1970 | 800 | 2734 | 818 | 800 | 2001 |
| RML60 | 360 | 173 | 6000 | 1970 | 2125 | 2797 | 881 | 800 | 2001 |
| RML75 | 300 | 196 | 7500 | 1970 | 2125 | 2860 | 945 | 800 | 2001 |

*Measurement uses standard REID fork attachment

Accessories

REID Offer a range of standard attachment accessories that can be used with any of the four RML model sizes, see page 4 for more information.

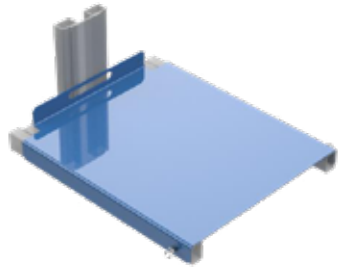

Load Platform

Allowing items that require additional support to be lifted on a flat platform.



Fork Extensions

These add support to larger dimension objects

Max length 1070mm



Pipe Cradle

Ideal for supporting pipes and ducting in M&E applications



Boom Arm

Often used for shackle loads or in many cases with the addition of a glass lifting solution.

1070mm length



Counterbalance Basket

Add to any system to convert to the counterbalance configuration



20kg Hand Weight

200kg Required for Counterbalance use

All information herein is copyright protected by REID Lifting Ltd. All company and product names are Trade Mark and Trade Name protected and all REID Product IPR is protected under Patents, Patents Pending and/or Design Rights.



Printed using environment friendly processes and materials.

REID Lifting

Unit 1 Wyeview,
Newhouse Farm Ind. Estate
Chepstow, Monmouthshire
NP16 6UD UK

➤ +44 (0)1291 620 796
➤ enquiries@reidlifting.com
➤ www.reidlifting.com